

SECTION A-A
FULL SECTIONAL FRONT VIEW

LEFT SIDE VIEW

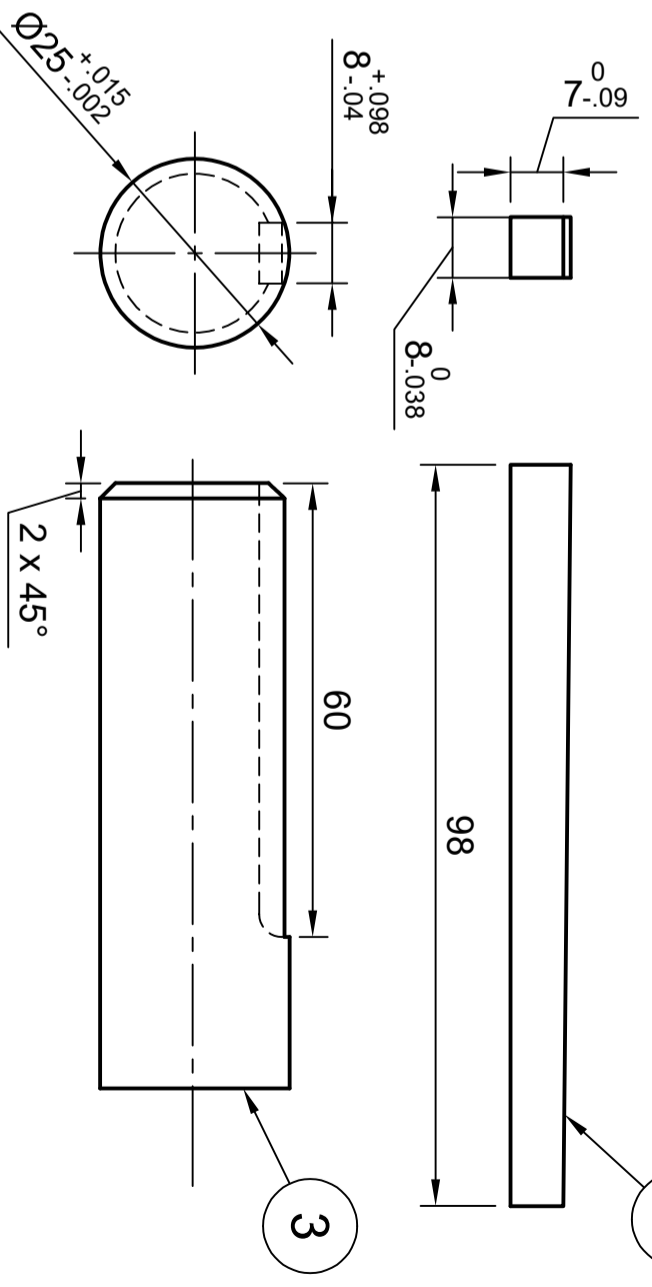
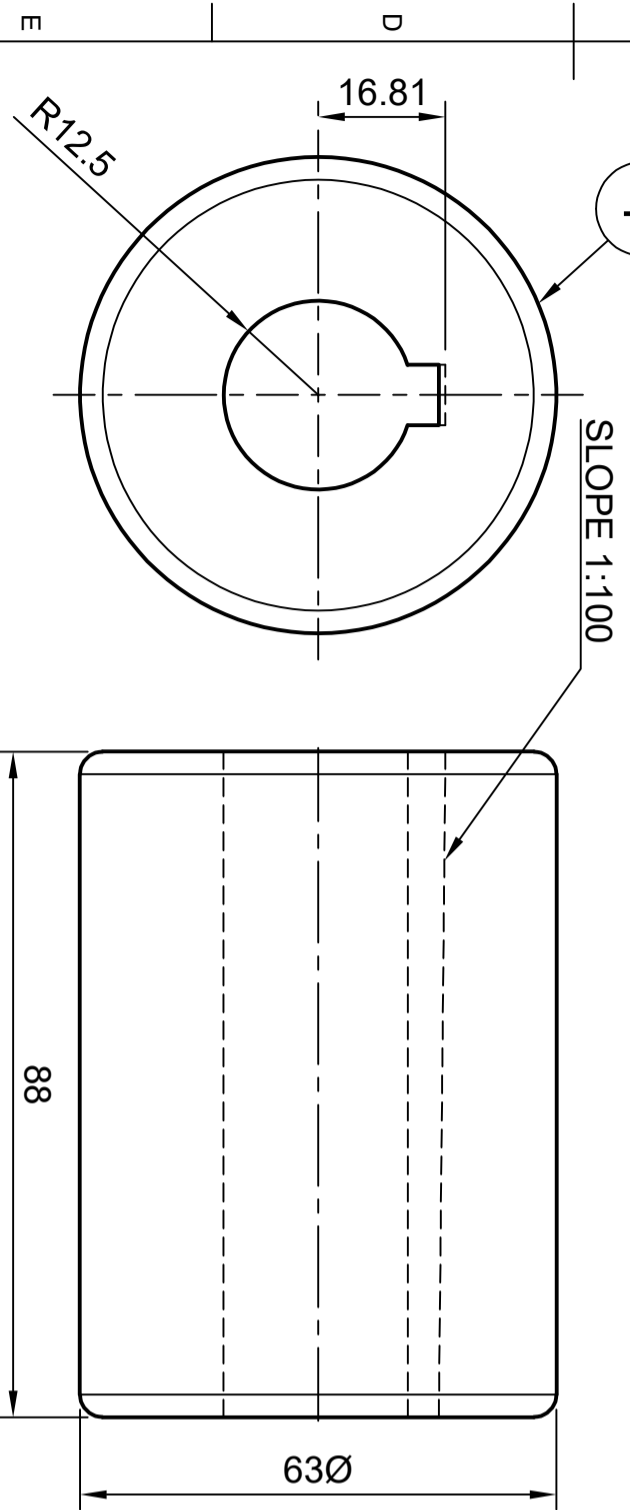

ALL DIMENSIONS ARE IN MM
FILLET RADIUS R3 WHENEVER NOT SPECIFIED

4	1	#03	Taper Key	Iron, Gray Cast ASTM A48 Grade 30
3	1	#02	Shaft	Iron, Gray Cast ASTM A48 Grade 30
2	1	#02	Shaft	Iron, Gray Cast ASTM A48 Grade 30
1	1	#01	Muff Coupling	Iron, Cast

Dept.	Technical reference	Created by	Approved by
		John Reyman Cabios 2020-12-16	
Title		Document status	
Coupling Assembly		DWG No.	
Rev.	Date of issue	Sheet	
		1/1	